

Architecting Big Data

A Structural Blueprint of Management, Processing, and Modelling Frameworks

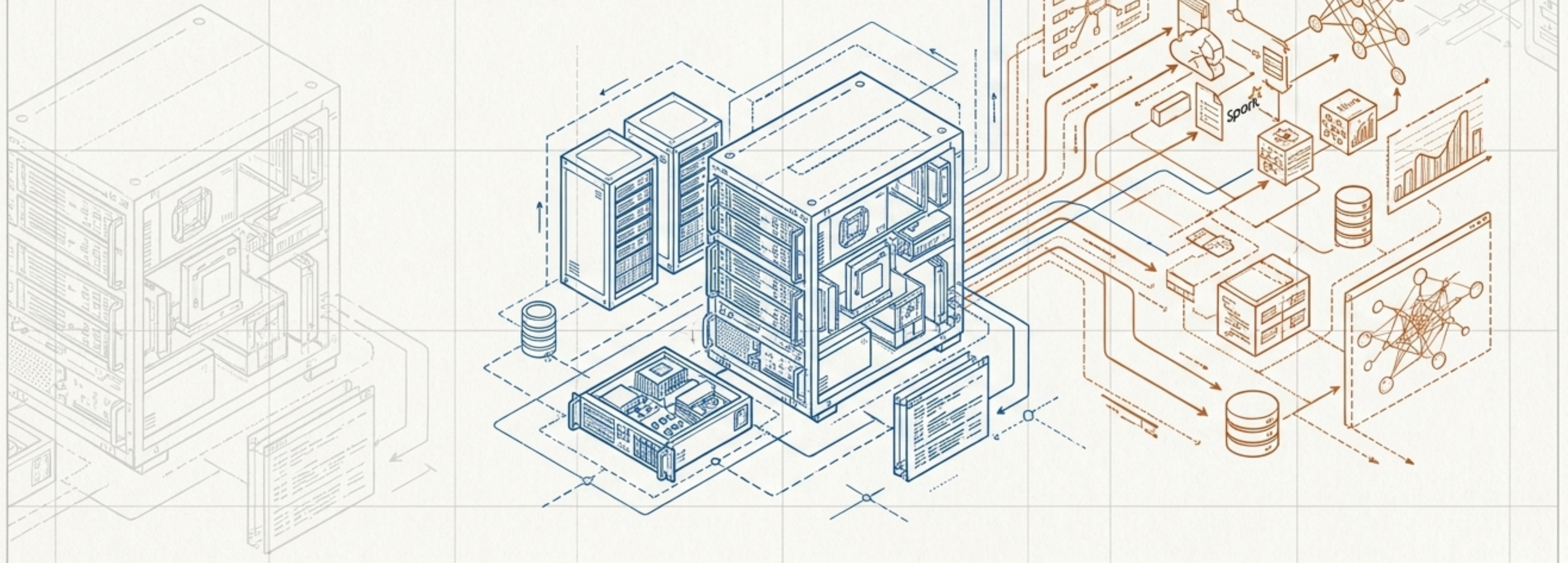

DATA REFINERY BLUEPRINT: MACRO-STRUCTURE OF BIG DATA ECOSYSTEM

MANAGEMENT

The infrastructural foundation. Focuses on physical storage, resource allocation, and raw programmatic data processing.

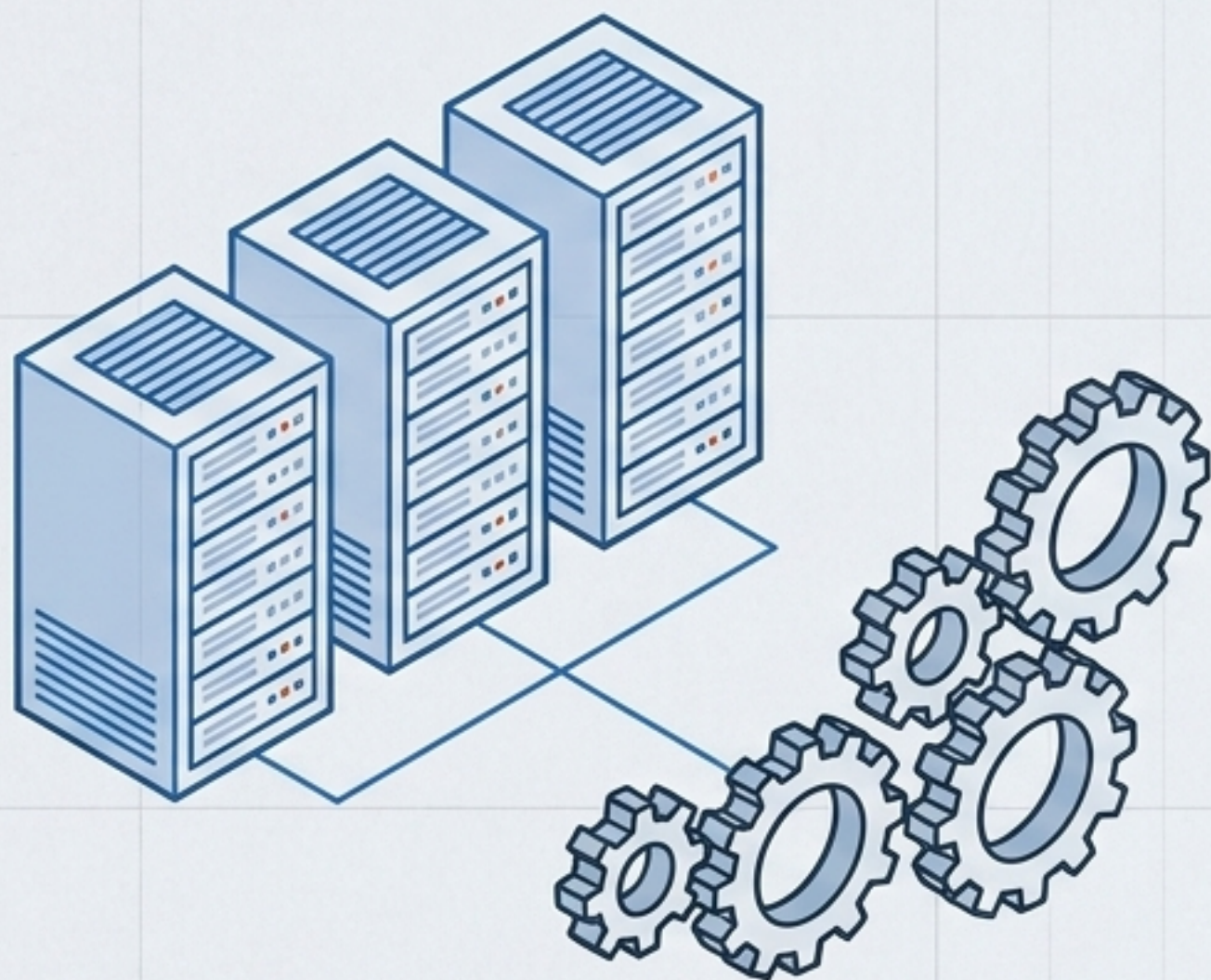

MODELLING

The access and structuring layer. Focuses on query-based processing, database architectures, and extracting insights.

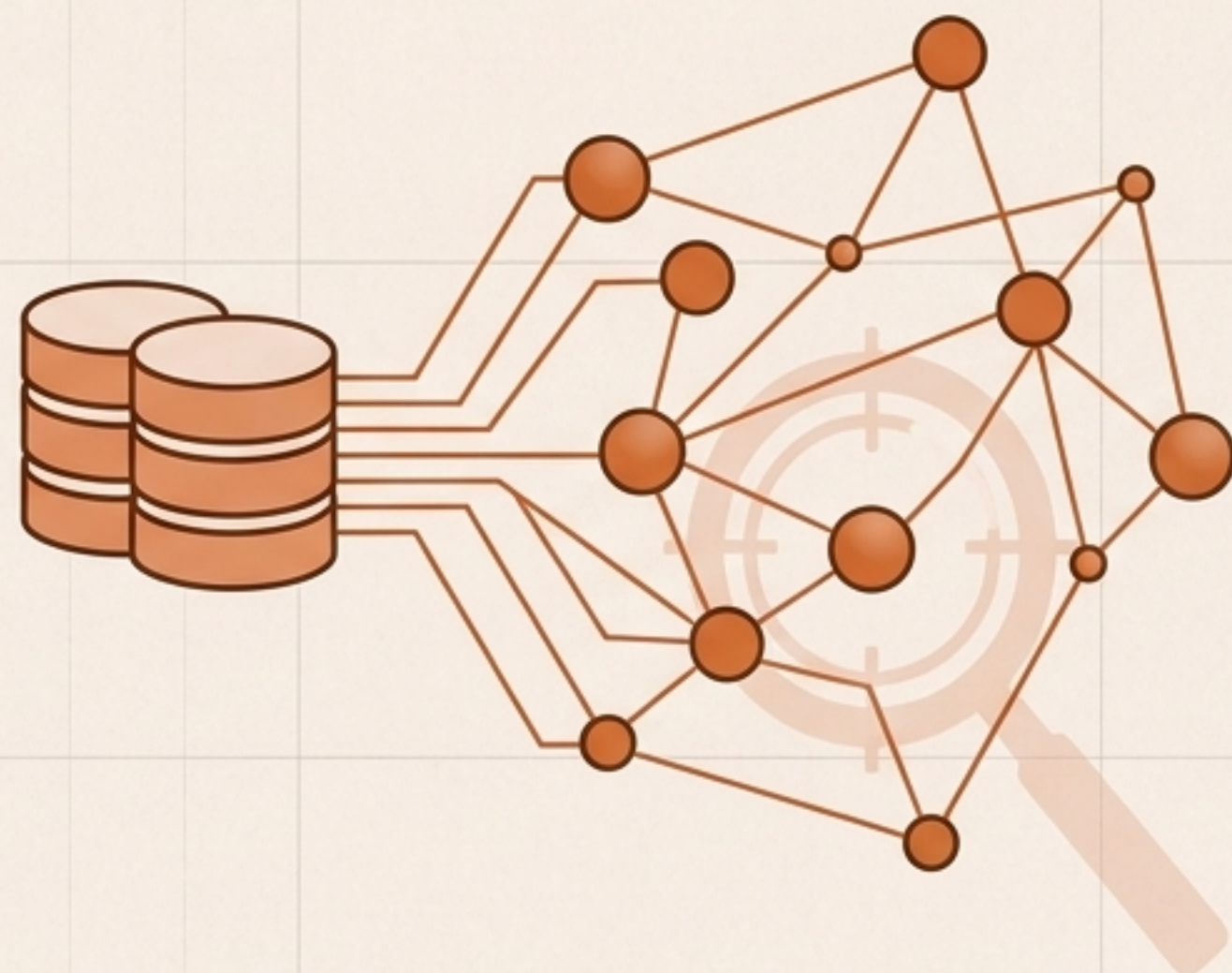

HADOOP ARCHITECTURE: MANAGEMENT LAYER SCHEMATIC

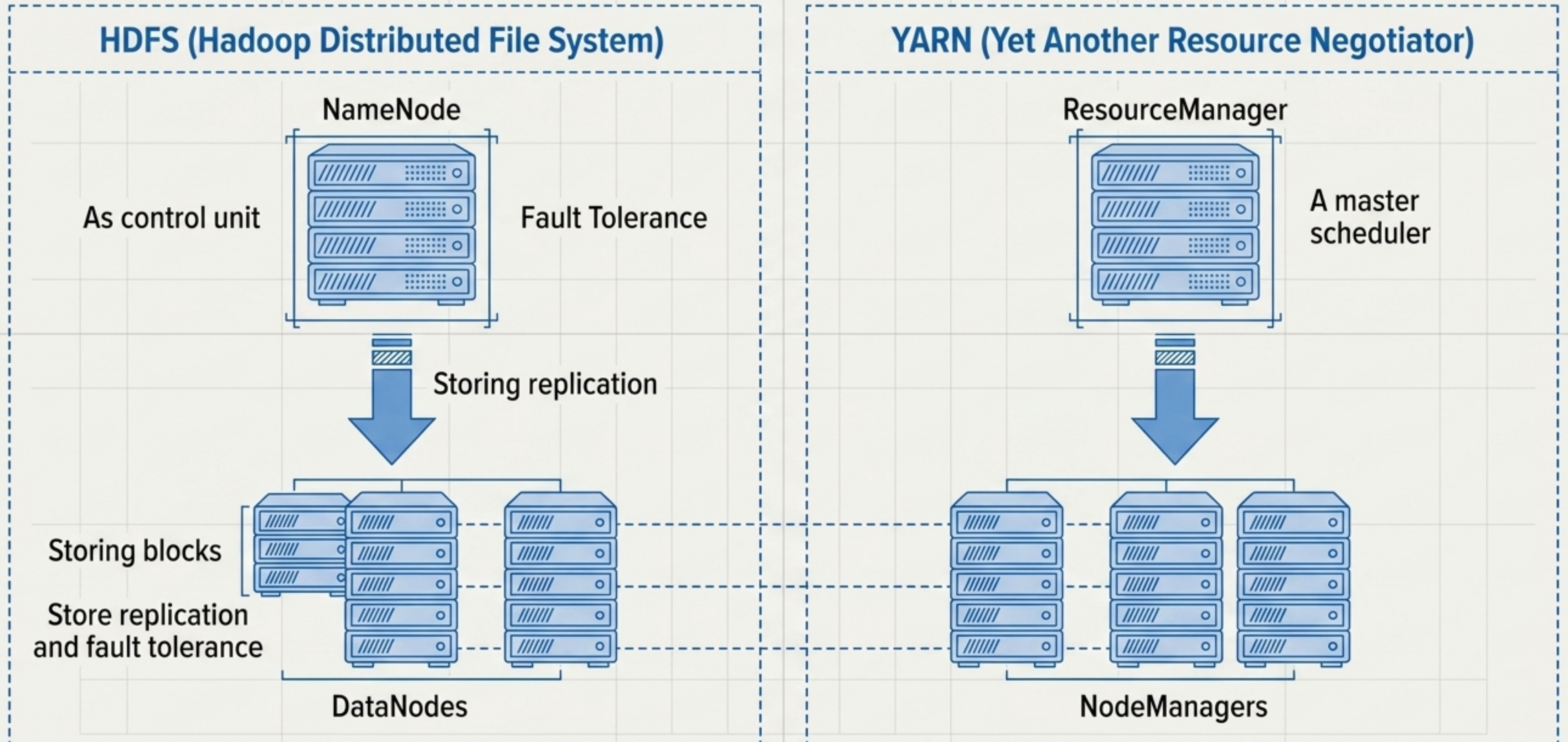

DATA REFINERY BLUEPRINT: PROCESSING SERVICES EVOLUTION

Tier 1

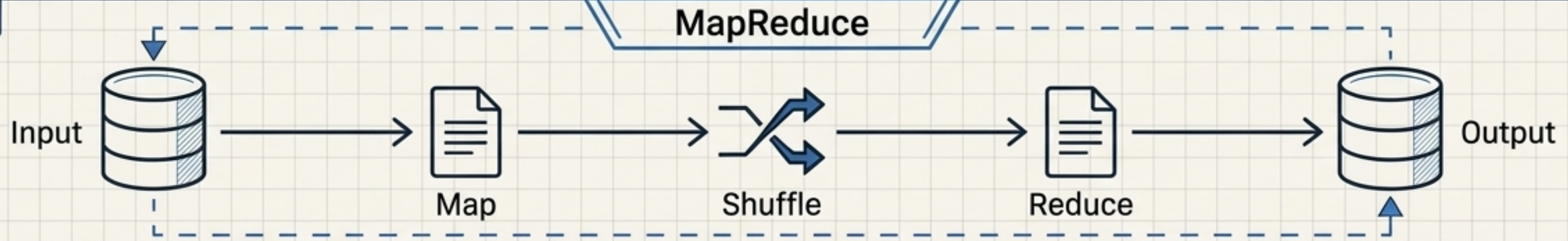

Tier 2

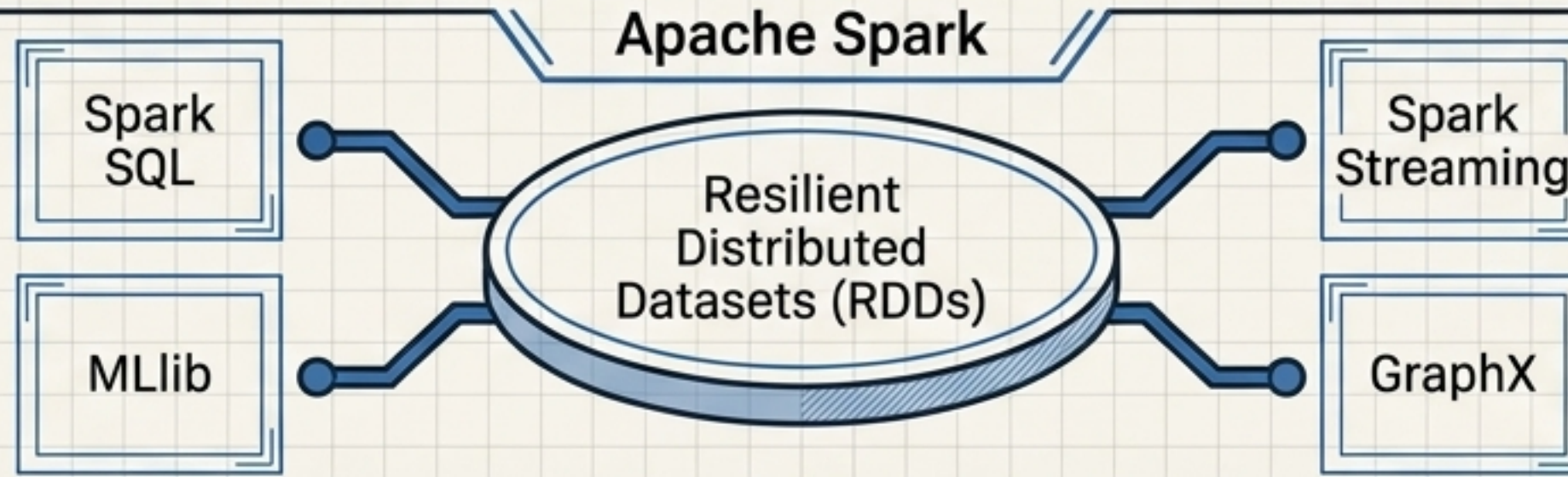

Tier 3

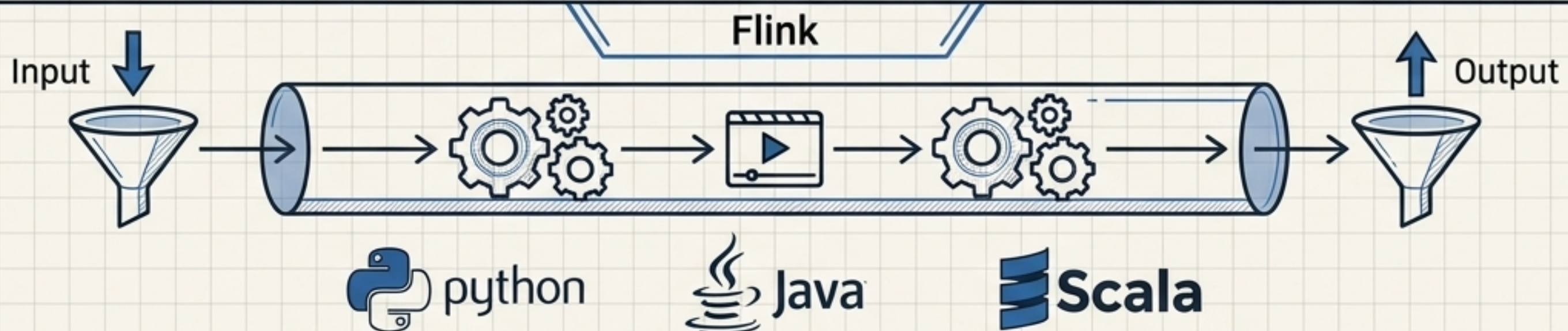

DATA REFINERY BLUEPRINT: SQL ENGINE COMPARISON MATRIX

Hive

Impala

Presto



Metastore

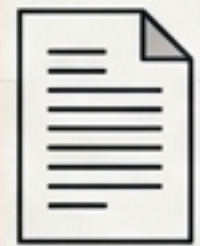

HiveQL

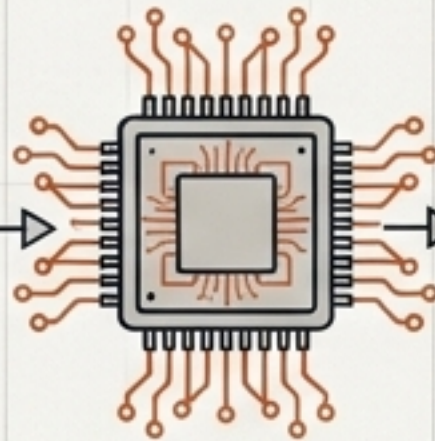

Execution Engine

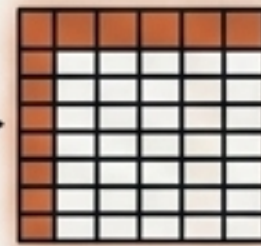

Realistic table

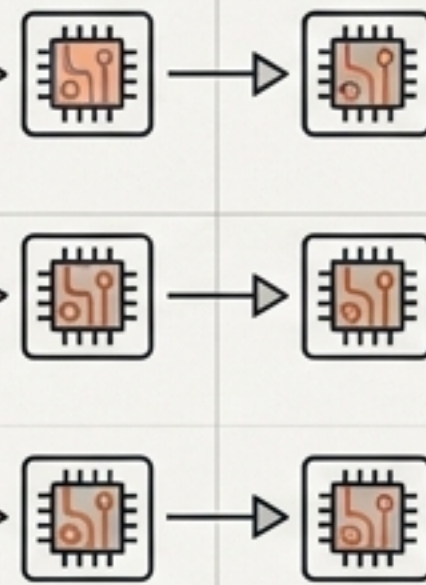

Low latency



Presto



Database



Database



Database

A Distributed SQL query engine for ad-hoc queries

DATA REFINERY BLUEPRINT: NOSQL DATABASE LANDSCAPE

Key-Value

Key and value pair

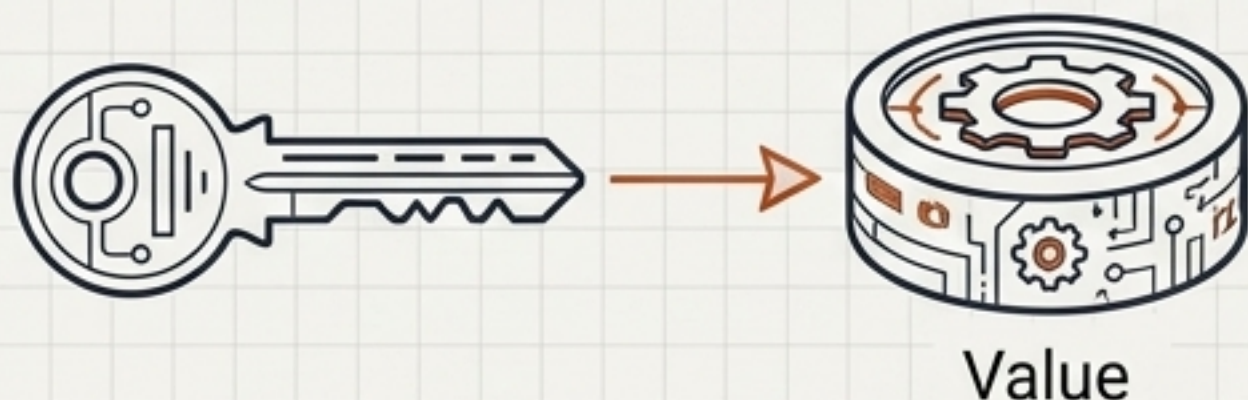

 Redis  Couchbase

Document

JSON/XML documents are nested data

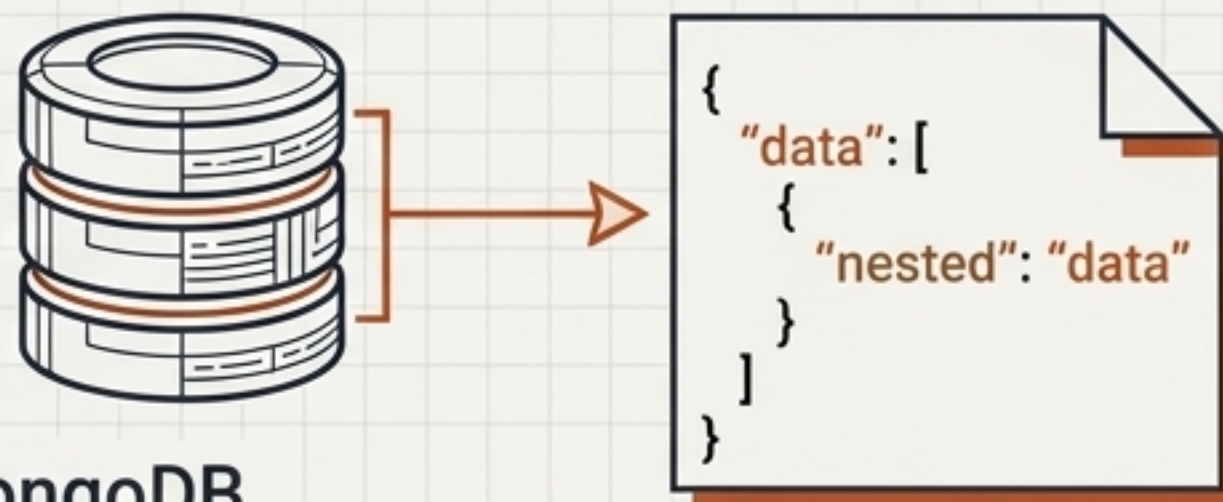

 MongoDB

Column-Family

Routing a wide-column store (realistic sparse data)



Cassandra 

Graph

Nodes and relationships

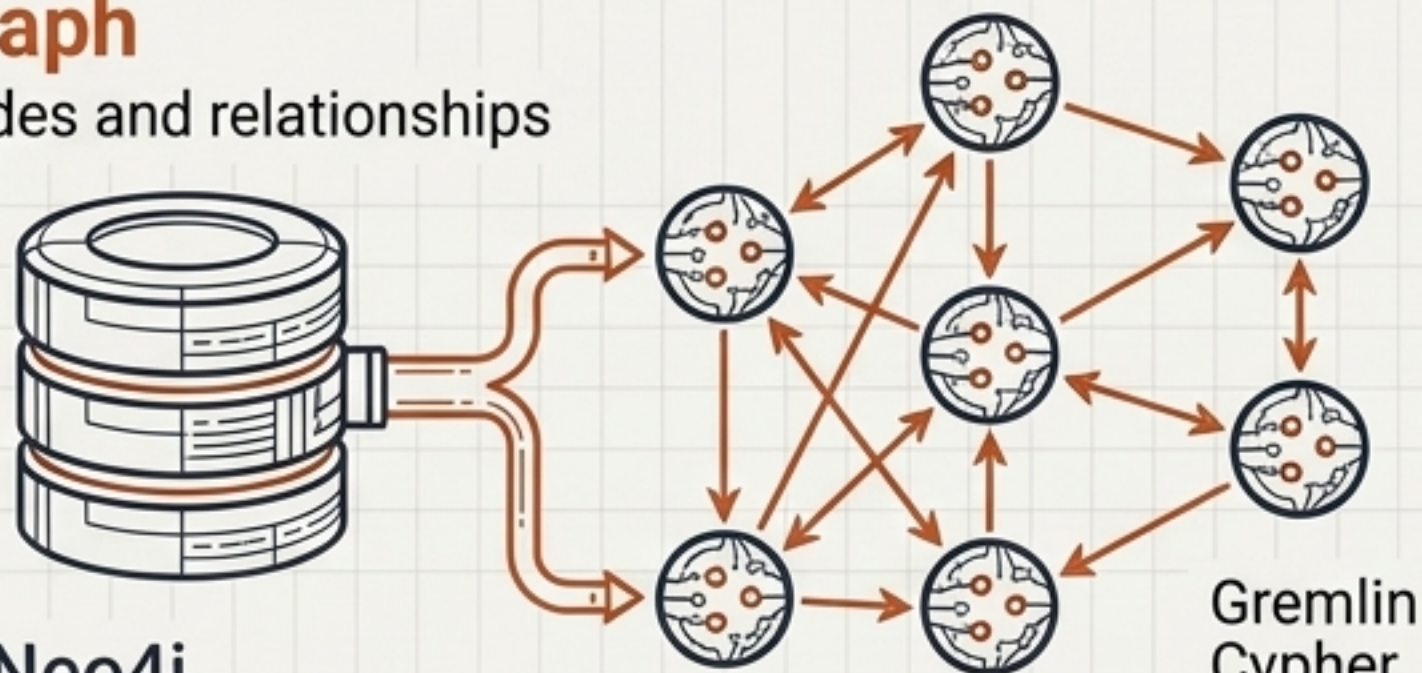

 Neo4j

Gremlin
Cypher

DATA REFINERY BLUEPRINT: ECOSYSTEM MASTER PIPELINE

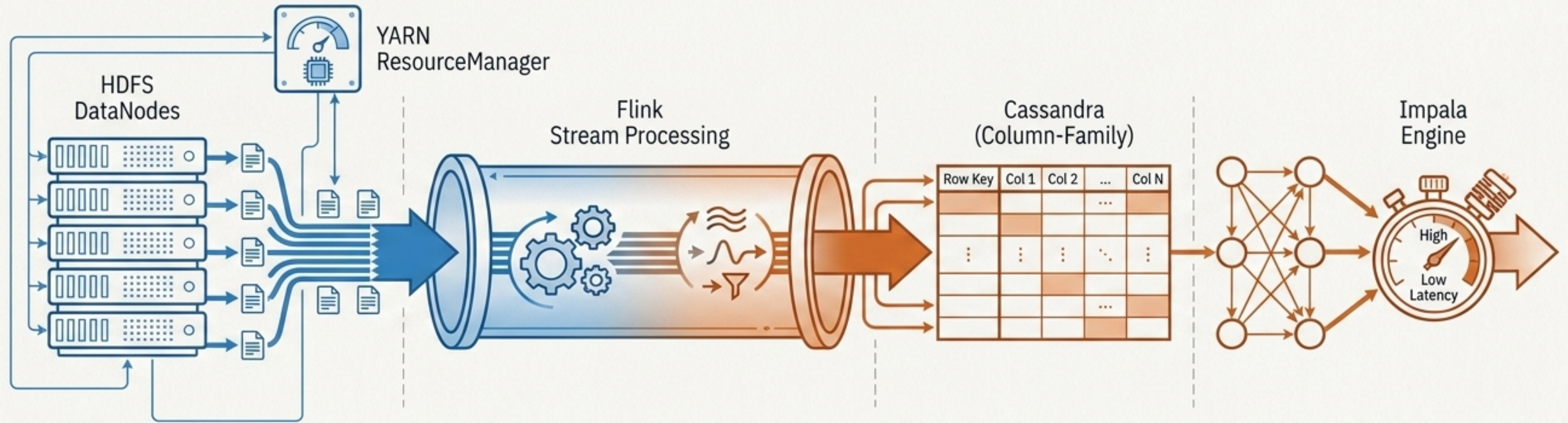

The Big Data ecosystem is not a collection of competing tools, but a highly specialized supply chain. Management frameworks handle the heavy lifting of storage and compute, while Modelling engines provide the agile, structured access required for human insight.